



WEIGHING SOLUTIONS FOR LOGISTICS

CATALOGUE

TWIN FORKS

WEIGHING FORKS

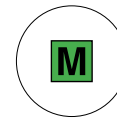

TWIN FORKS represent the easiest weighing solution for forklifts: they simply replace the standard forks transforming your forklift into an accurate approved mobile weighing station. Bluetooth connection, lithium battery and cutting-edge technology to guarantee the best performance.

Choose it because:

- Easy to mount and remove
- Very thin shape with minimum reduction of the lifting capacity
- Approved for legal-for-trade use

M	Max. Capacity (kg)	d (kg)	e (kg) M
*	2.500 [1.000 - 2.500]	1 - 2	2 - 5

Upon request:

- (*) Legal-for-trade-approval M
- Version for FEM2B fork-holder plates
- Version for FEM3A fork-holder plates

Other special versions upon request

Main Functions

- **WEIGHT TOTALISATION**
- **UNIT CONVERTER:** kg/lb, free conversion factor
- **ZEROING**
- **TARE**
- **PRESET TARE**

Main Features

Display	25 mm LCD backlit display	
Brightness	Adjustable brightness	
IP protection rating	Forks	IP66
	Indicator	IP67
Fixing bracket	As standard	
Accuracy	Internal use	± 2 kg
	Legal for trade M	In accordance with Directive 2014/31/EU
Keyboard	5 keys waterproof	
Fork structure	Sturdy painted steel	
Fork connection	FEM2A *(FEM2B and FEM3A upon request)	
Fork weigh	68 kg	
Max. horizontal inclination	± 2° (for legal for trade use only)	
Max. barycentric shifting	25 mm	
Load cells	4, in stainless steel, with IP68 protection	
Max. allowable overload	More than 300% F.S.	
Auto switch-off	5 min, programmable	
Switch-on	Automatic switch-on function, thanks to the movement detector	
Power supply	Forks	Rechargeable lithium battery with Instaplug technology with EU, UK, AU, US power plugs
	Indicator	5 V, from forklift truck
Operating time	Up to 90 h or 24/7 continuous use with optional battery kit	
Operating temperature range	-10 / +40 °C	
Forks communication	Bluetooth technology	
Communication to external devices	Communication port for optional printer	

Certifications

- 2014/30/EU (EMC)
- 2014/35/EU (LVD)
- 2011/65/EU (RoHS)
- 2014/31/EU (NAWI)

Technical Drawing (mm)

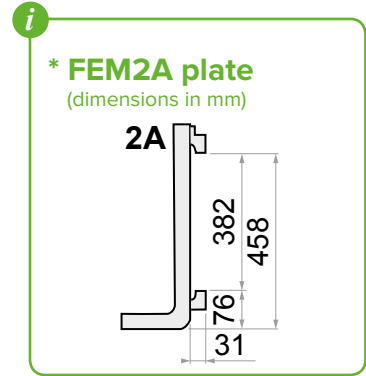
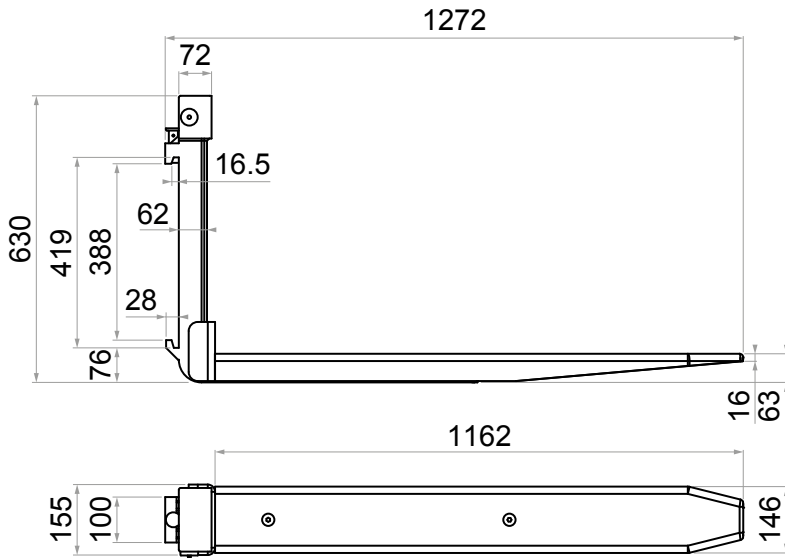

Technical Drawing | COMPACT Weight Indicator (mm)

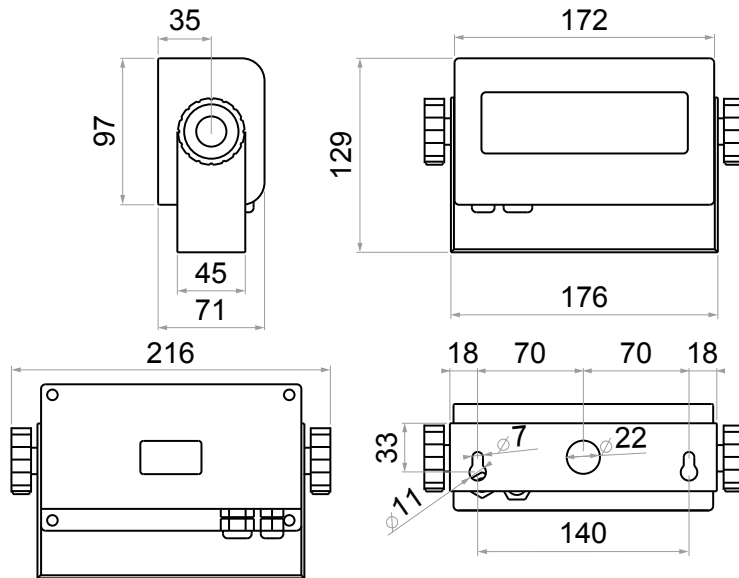

Accessories

- THERMAL PRINTER
- DATE AND TIME
- FIXING BRACKETS FOR INDICATOR