



# WEIGHING SOLUTIONS FOR LOGISTICS

CATALOGUE

# TPWLK

LEGAL FOR TRADE WITH PRINTER

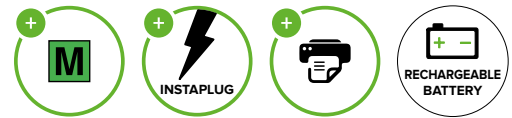

550 mm  
EUROPALLET



680 mm  
US PALLET



MANUFACTURED  
IN ITALY

Professional pallet truck scale, with optional printer ideal for tracking weighing. Certified accuracy thanks to the legal-for-trade approval.

Choose it because:

- Approved for legal-for-trade use
- Also available with integrated printer
- Instaplug technology that allows for 24/7 use

M	Printer	Max. Capacity (kg)	d (kg)	e (kg)
		<b>2.000</b>	0,2	
M		<b>2.000</b> [ 1.000 - 2.000 ]		0,5 - 1
	Printer	<b>2.000</b>	0,2	
M	Printer	<b>2.000</b> [ 1.000 - 2.000 ]		0,5 - 1

M Legal for trade. Printer Integrated Printer and Date & Time.

Upon request:

- M Capacity 600 kg, Resolution 0,2 kg
- M Capacity 600 / 1.500 kg, Resolution 0,2 / 0,5 kg
- M Capacity 1.500 kg
- M Capacity 2.500 kg
- Capacity 2.500 kg (Accuracy between 2.000 / 2.500 kg is 2 kg)
- Forks for US pallet (680 mm)

Other special capacities / resolutions: upon request.

Other special versions: upon request.

## Main Functions

- WEIGHT TOTALISATION
- PIECE COUNTING
- UNIT CONVERTER: kg/lb, free conversion factor
- 50 TARE MEMORY
- PRINT NUMERIC IDs
- ZEROING
- TARE
- PRESET TARE

## Main Features

Display	25 mm LCD backlit display	
Brightness	Adjustable brightness	
IP protection rating	IP65 / IP20 for models with printer	
Accuracy*	Internal use	± 1 kg
	Legal for trade M	In accordance with Directive 2014/31/EU
Keyboard	17-key waterproof	
Structure	Oven-fire painted steel	
Steering wheels	Double polyurethane rollers	
Load wheels	Double polyurethane loading rollers	
Lift pump	Quick-lifting hydraulic pump	
Load cells	4, in stainless steel, with IP68 protection	
Auto switch-off	5 min, programmable	
Power supply	"Instaplug" removable rechargeable battery	
Operating time	About 80 h	
Battery recharge	Via a 230 Vac 50 Hz charger (8 h for full recharge) with EU power plug**	
Operating temperature range	-10 / +40 °C	
Communication to external devices	Optional radio-frequency, Wi-Fi or Bluetooth	

(\*) Weighing of goods on EUROPALLET with distributed load.

(\*\*) UK, AU, US versions: upon request.

## Certifications

- 2006/42/EU (Machine Directive)
- 2014/30/EU (EMC)
- 2014/35/EU (LVD)
- 2011/65/EU (RoHS)
- 2014/31/EU (NAWI)

## Technical Drawing (mm)

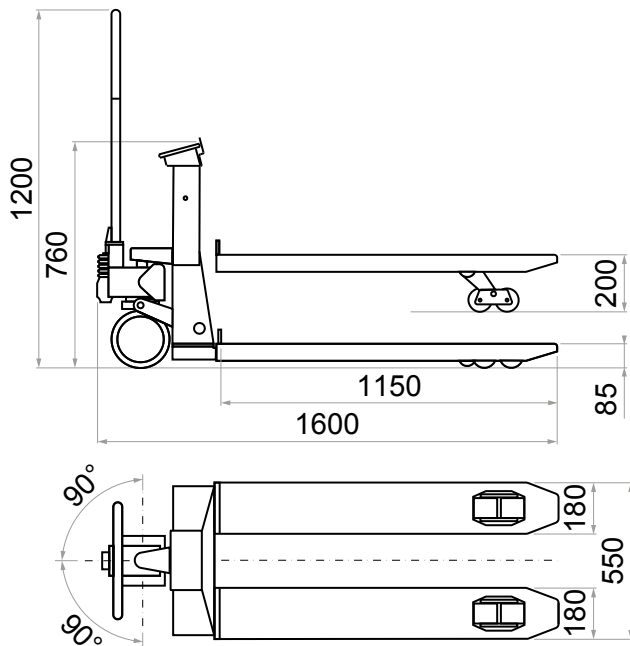

## Accessories

- ADDITIONAL BATTERY FOR 24/7 USE
- BLUETOOTH INTERFACE
- RADIO 2,4 GHz INTERFACE
- Wi-Fi
- PC SOFTWARE FOR DATA STORAGE
- FISCAL MEMORY
- PARKING BRAKE
- USB MEMORY FOR DATA STORAGE
- ANTISTATIC STEERING WHEELS
- VULKOLLAN / NYLON STEERING WHEELS

Robust packaging for optimal protection  
of your pallet truck.  
*100% recyclable.*