

Mini Self-propelled Scissor Lifts (Electric Motor Drive) Specification

		HANGCHA GROUP CO.,LTD.	
01	Manufacturer		
02	Model	60XEND	76XEND
03	Working height	(m/in)	5.9/233
04	Platform height	(m/in)	3.9/153
05	Overall length	(m/in)	1.44/57
06	Overall width	(m/in)	0.76/30
07	Overall height	(m/in)	2.08/81.8
08	Height with rails folded	(m/in)	1.71/67.3
09	Platform size	(m/in)	1.29×0.7/50.8×27.5
10	Platform extension size	(m/in)	0.6/23.6
11	Ground clearance	(m/in)	0.06/2.4
12	Turning radius inside	(m/in)	0.4/15.7
13	Turning radius outside	(m/in)	1.55/61
14	Rated load	(kg/lb)	250/551
15	Load on extension	(kg/lb)	113/250
16	Batteries	(V/AH)	24,80
17	Weight ±30	(kg/lb)	900/1984
18	Travel speed km/h	(mph)	0~4(0~2.48)
19	Lift time	(s)	32
20	Lowered time	(s)	27
21	Tyre		Non-mark Tyres
22	Maximum slope		2°/3°
23	Gradeability		30%
24	Working area		"indoor 0km/h(0mph) outdoor 12.5km/h(7.7mph)"

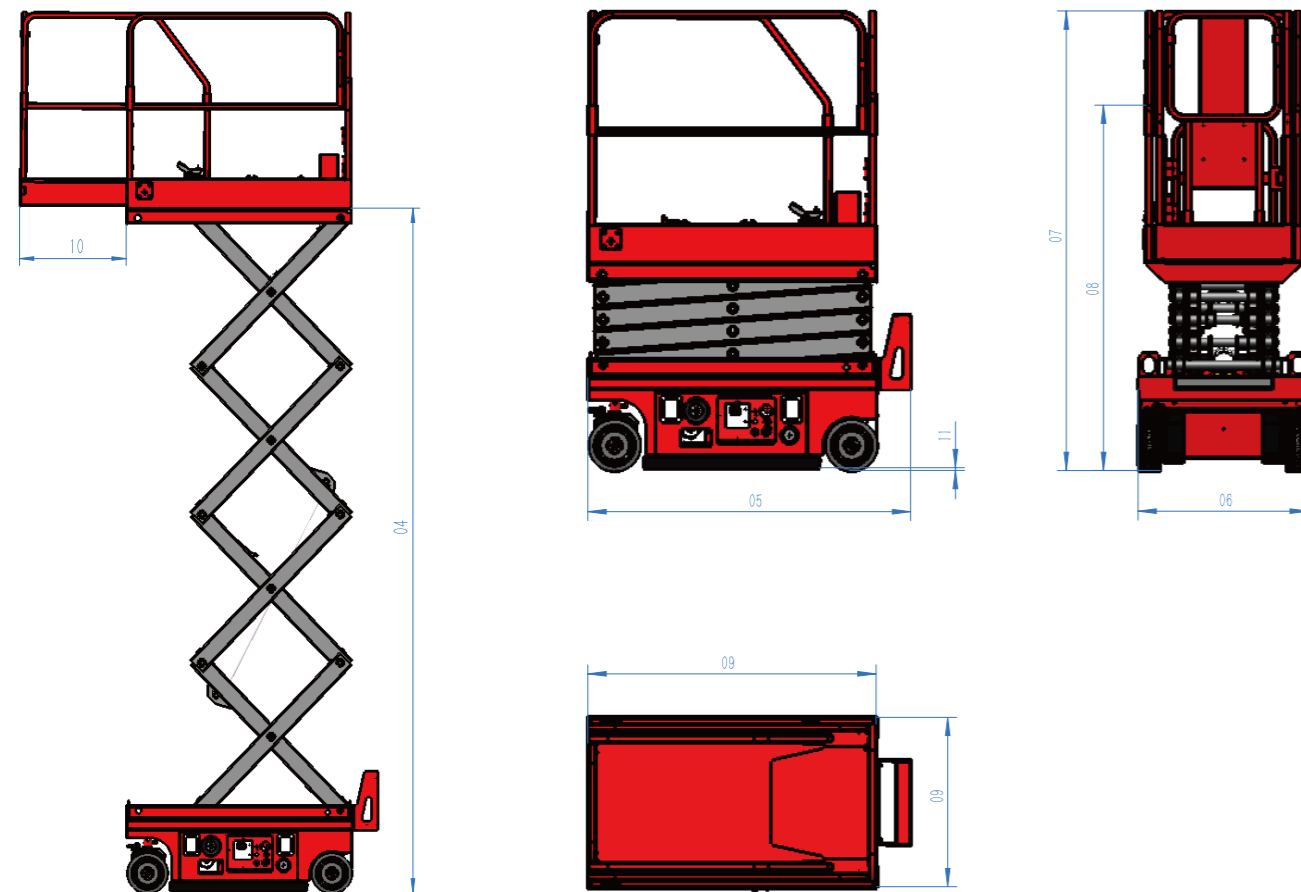

ZHEJIANG HANGCHA IMP. & EXP. CO., LTD.

Factory site: 666 Xiangfu Road,
Hangzhou, Zhejiang, China (311305)

Tel: +86-571-88926735 88926755
Fax: +86-571-88926789 88132890

sales@hcforklift.com
www.hcforklift.com



HANGCHA GROUP CO., LTD. reserves the right to make any changes without notice concerning colors, equipment, or specifications detailed in this brochure, or to discontinue individual models. The colors of trucks, delivered may differ slightly from those in brochures.

Mini Self-propelled Scissor Lifts (Electric Motor Drive)

Aerial work platform



The World of Hangcha
SINCE 1956





Anti-overturning system, When the machine raises to more than 2m, this system will work automatically, to protect the machine from overturning while walking at un-leveling ground



Manual lowering handle, When the operation system failed or the battery power is too low to let the platform decline, we can use this handle to lower the machine



LCD screen, used to display fault code and adjust parameters



Supporting arms, To protect the operator when he is doing repair or maintenance job

Designed to be used in buildings

/ The working height can perfectly adapt to the needs of building working.

Mini Size

/ The compact size makes the machine gets into the elevator with free access.

Light Weight

/ The weight is very light, which can meet the load limit of elevator and better protect the ground.

Large Capacity

/ Though the self-weight is light, it has a large capacity, the machine can allow two peoples working together.

High Efficiency

/ Equipped with efficient fully electrified DC drive system, more durable.

Low Failure Rate

/ Simple and clear system, drawer structure, easier maintenance, lower use cost.

High Rewarding

/ Transport and procurement costs are lower, and rental prices are comparable to regular models.

Green Environment Protection

/ Electric drive walking system, zero emission, low noise, more suitable for indoor use.



Control system

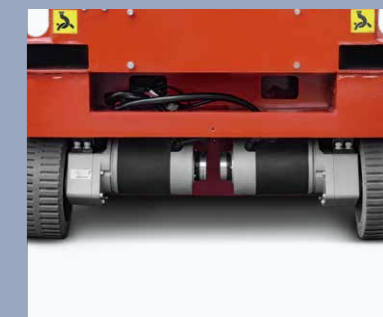

Motor and brake



Explosion proof valve, To prevent the machine falling when the oil pipe is leaking



Extension platform



The parts are well located