

Precise Pallet Handling In Narrow Aisle Racking Systems

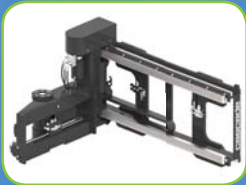

Full length traversing function left and right - swing functioning 90° left and right for versatility

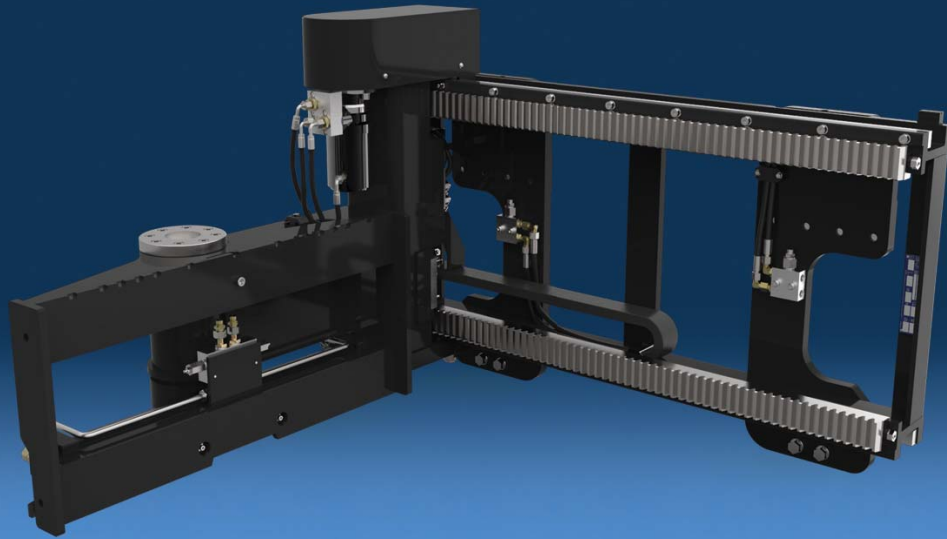

Motor with brake maintains the position of the load during the movement of the truck for secure handling



Adjustable racks, pinion and wear plate are heat treated for longer life



Rotation rack cylinder with end dampener reduces the impact at the end of swing stop



Eccentric roller pins adjust tolerance between rack & pinion to maintain smoothness

APPLICATIONS

The Cascade Trilateral Head attachment is the perfect solution for handling pallets in applications with narrow aisle racking systems. The Trilateral Head attachment is designed for trucks being used in narrow aisle warehouses, featuring a traversing fork system allowing you to retrieve pallets from shelving while your truck remains at a 90° angle to the load.

FEATURES

- Swing function allows to handle loads from either centre, left or right hand of the truck.
- Traversing Head allows forks to enter and pickup/deposit from either centre, left or right hand side of the truck.
- Uses Class 2 ITA fork mounting (hook-on forks as option).
- Motor brake maintains the position of the load during truck movement.
- Eccentric pins allow for adjusting tolerance between rack & pinion for smooth operation.
- Rack and pinions heat treated to ensure longer life and reliability.
- Rack cylinder with end dampener to reduce impact at the end of swing stop.
- Optimised design to allow easy and fast maintenance.

OPTIONS

- 0°/ +3° tilting fork carriage.
- Fork positioner on fork carriage.
- Custom designs for stacker crane.
- Load backrest upon request.
- Available with special optimised mast upon request.

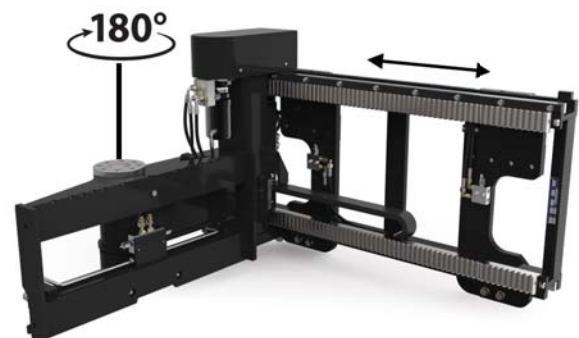

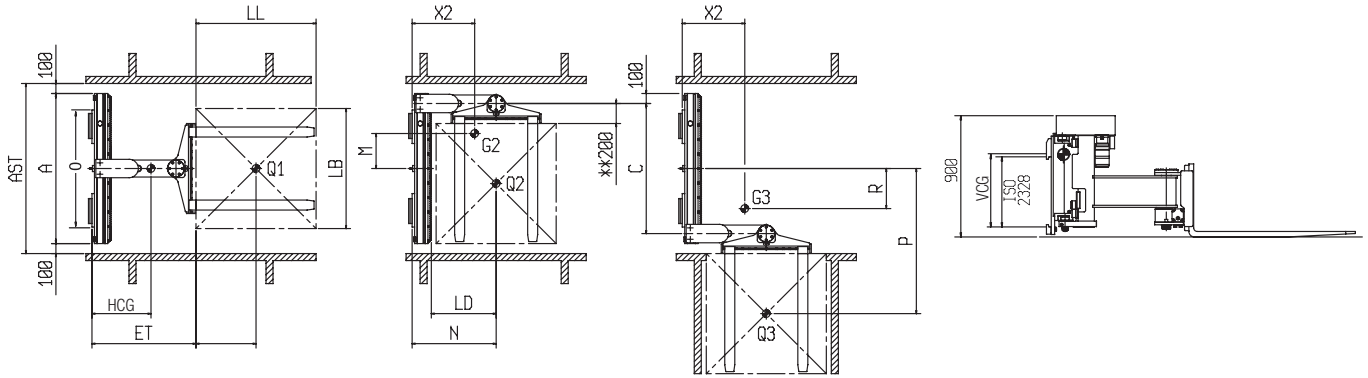

Catalogue Order No.	Q1-Capacity @ Load Centre kg@mm	Pallet dimensions (mm) LL/LB	Frame width (mm) A/AST	G2/Q2 (mm) M/N/X2	G3/Q3 (mm) P/R	Stroke (mm) C	Frame to LC (Q2) (mm) LD	Effective thickness (mm) ET	Min. Truck Carriage Width O	Horizontal Centre of gravity (mm) HCG	Vertical Centre of gravity (mm) VCG	Weight kg	Mounting Class [Ⓛ] ISO 2328
8A-AST-2A-1010	800@500	1000/1000	1300/1500	290 / 740 / 335	1250/360	1100	548	940	1100	345	340	540	2A
8A-AST-2A-1210	800@600	1200/1000	1500/1700	340 / 740 / 330	1450/400	1300	548	940	1100	340	340	560	2A
8A-AST-2A-1012	800@500	1000/1200	1300/1500	295 / 840 / 355	1250/365	1100	648	1040	1100	375	340	548	2A
8A-AST-2A-1212	800@600	1200/1200	1500/1700	345 / 840 / 350	1450/405	1300	648	1040	1100	370	340	568	2A
12A-AST-2A-1010	1200@500	1000/1000	1300/1500	290 / 740 / 335	1250/360	1100	548	940	1100	340	340	558	2A
12A-AST-2A-1210	1200@600	1200/1000	1500/1700	340 / 740 / 330	1450/400	1300	548	940	1100	335	340	578	2A
12A-AST-2A-1012	1200@500	1000/1200	1300/1500	295 / 840 / 355	1250/365	1100	648	1040	1100	370	340	566	2A
12A-AST-2A-1212	1200@600	1200/1200	1500/1700	345 / 840 / 350	1450/405	1300	648	1040	1100	365	340	586	2A
12A-AST-3A-1010	1200@500	1000/1000	1300/1500	290 / 740 / 335	1250/360	1100	548	940	1100	340	340	558	3A
12A-AST-3A-1210	1200@600	1200/1000	1500/1700	340 / 740 / 330	1450/400	1300	548	940	1100	335	340	578	3A
12A-AST-3A-1012	1200@500	1000/1200	1300/1500	295 / 840 / 355	1250/365	1100	648	1040	1100	370	340	566	3A
12A-AST-3A-1212	1200@600	1200/1200	1500/1700	345 / 840 / 350	1450/405	1300	648	1040	1100	365	340	586	3A
16A-AST-3A-1010	1600@500	1000/1000	1300/1500	305 / 745 / 345	1250/365	1100	548	945	1100	415	340	635	3A
16A-AST-3A-1210	1600@600	1200/1000	1500/1700	360 / 745 / 340	1450/405	1300	548	945	1100	410	340	655	3A
16A-AST-3A-1012	1600@500	1000/1200	1300/1500	310 / 845 / 365	1250/370	1100	648	1045	1100	435	340	645	3A
16A-AST-3A-1212	1600@600	1200/1200	1500/1700	380 / 845 / 360	1450/410	1300	648	1045	1100	430	340	665	3A

▶ Consult truck OEM to assure proper mast and tire setup to get a rated data plate created.

- Ⓛ Integral mounting available. ▶ Front carriage Class 2 ISO-2328.
- ▶ Forks are not included. ▶ Recommended hydraulic flow 12L/min (tolerance ± 1L).
- ▶ When ordering, specify truck mounting. ▶ Available with special optimised mast upon request.
- ▶ Supplied with double acting relief valves for both functions. ▶ ET includes fork thickness of 40mm.

Warehousing Equipment as Stacker Crane

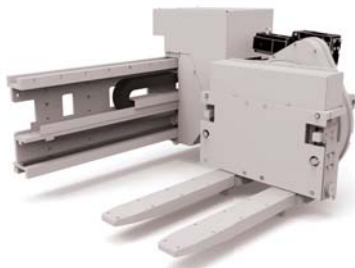

**Warehousing Equipment
Stacker Crane - LGV market**

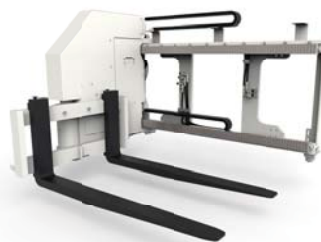

AGV/LGV applications

