

## WS Series Electric Pallet Truck With Lithium Battery Specification

		HANGCHA GROUP CO.,LTD.					
		Model	CBD18-WS-5E	CBD15-WS-6SL	CBD15-WS	CBD20-WS	
Characteristics	1.1 Capacity	kg	2000	1500	1500	2000	
	1.2 Load center	mm	600	600	600	600	
	1.3 Overall fork width	mm	550/685	550/685	520/550/685	550/685	
	1.4 Fork length	mm	1150/1220	1150/1220	1150/1220	1150/1220	
	1.5 Overall length	mm	1552/1622	1552/1622	1552/1622	1552/1622	
	1.6 Overall height of fork	mm	82±2	65±2	82±2	82±2	
	1.7 Max.height of fork	mm	197	165	197	197	
	1.8 Overall height (with tiller)	mm	1276	1250	1276	1276	
	1.9 Rear body width	mm	550/685	550/685	520/550/685	550/685	
	1.10 Minimum turning radius	mm	1353/1426	1353/1426	1353/1426	1353/1426	
Performance	2.1 Max.Traveling speed	laden	km/h	4	4	4	4
		unladen	km/h	5	5	5	5
	2.2 Gradeability	laden	%	6	6	6	6
		unladen	%	20	20	20	20
2.3 Traveling	kw	DC 0.75 Brushless	DC 0.75 Brushless	DC 0.75 Brushless	DC 1.0 Brushless		
2.4 Lifting	kw	Hydraulic	DC 0.8	DC 0.8	DC 0.8		
Battery	4.1 Voltage	v	48	48	48	48	
	4.2 Capacity/type	Ah	10 Ah Lithium	10 Ah Lithium	10 Ah Lithium	10 Ah Lithium	
Brake type	5.1 Travel brake		Regenerate	Regenerate	Regenerate	Regenerate	
	5.2 Brake		Electromagnetic	Electromagnetic	Electromagnetic	Electromagnetic	
Controller	6.1 Controller		B1503	B1503	B1503	B1503	

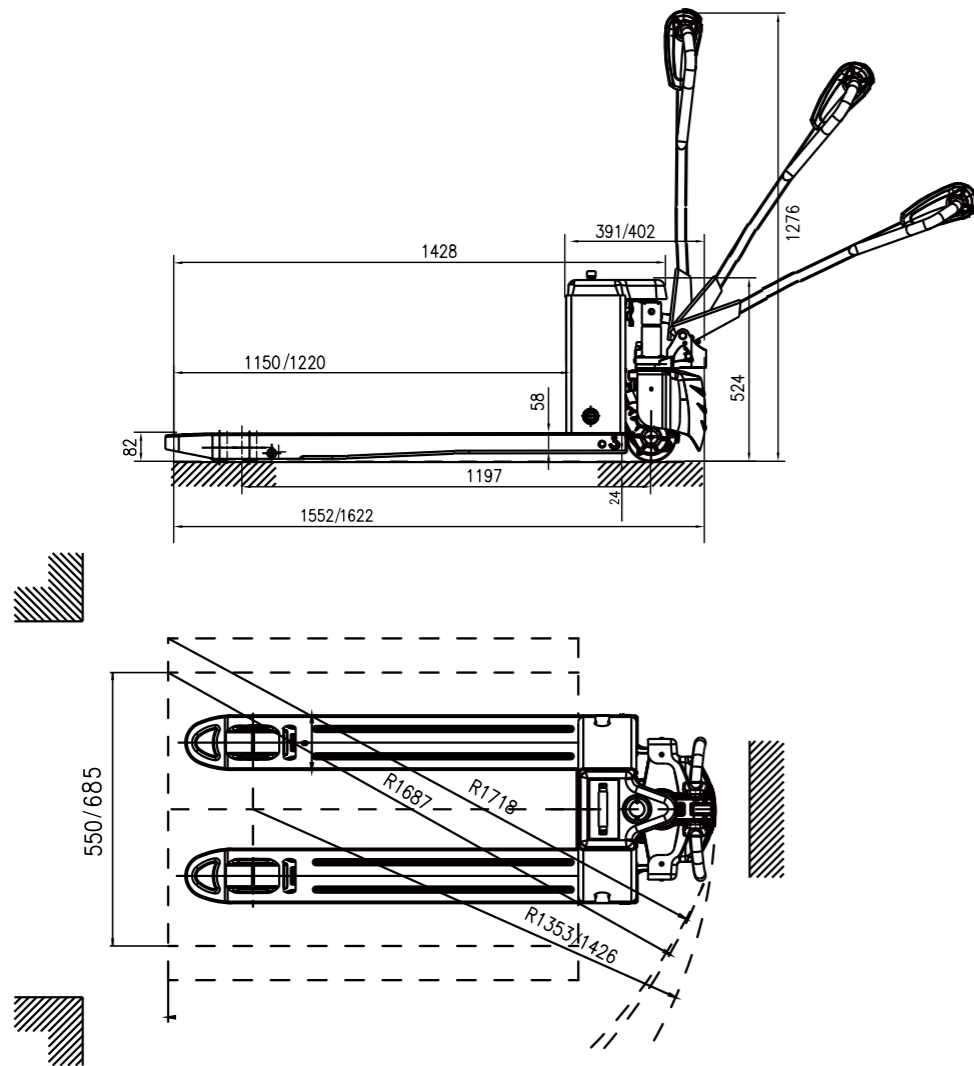

ZHEJIANG HANGCHA IMP. & EXP. CO., LTD.

Factory site: 666 Xiangfu Road,  
Hangzhou, Zhejiang, China (311305)

Tel: +86-571-88926735 88926755  
Fax: +86-571-88926789 88132890

sales@hcforklift.com  
www.hcforklift.com



Follow us on  
Facebook



Follow us on  
YouTube



Follow us on  
WeChat



ISO14001  
ISO14001:2015



ISO9001  
ISO9001:2015



HANGCHA trucks conform  
to the European Safety  
Requirements.

HANGCHA GROUP CO., LTD. reserves the right to make any changes without notice concerning colors, equipment, or specifications detailed in this brochure, or to discontinue individual models. The colors of trucks, delivered may differ slightly from those in brochures.

2019 VERSION / COPYRIGHT 2019/12



## WS Series Electric Pallet Truck With Lithium Battery

with capacities of 1,500/1,800/2,000kg

The World of Hangcha  
SINCE 1956



# PERFORMANCE

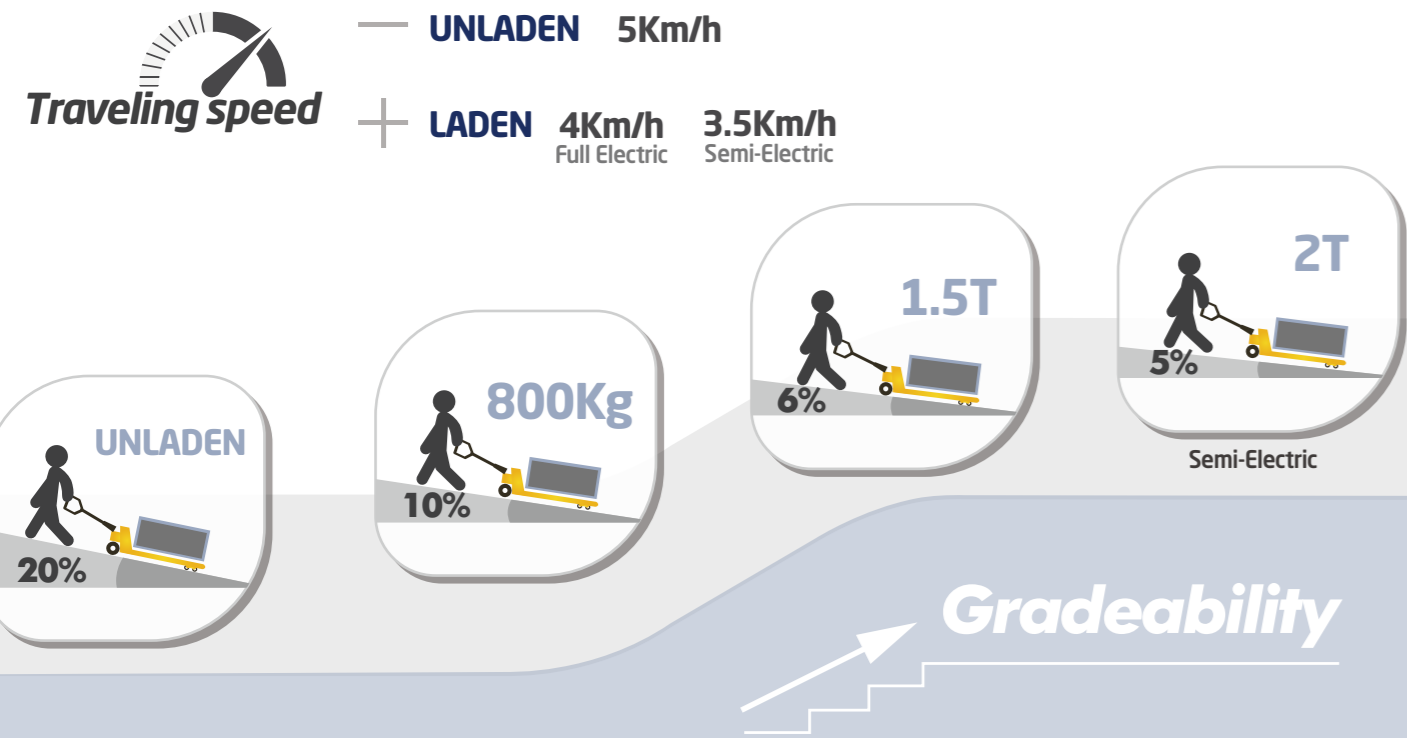

# SMART FUNCTION

### SMART FUNCTION 01

**Turtle Speed**  
Horn Remains Pressed & Forward 2 times

### SMART FUNCTION 02

**Up-Right Drive**  
Reverse Button & Forward Throttle Remain Pressed, Power On

### SMART FUNCTION 03

**Engineering Mode (Brake Release)**  
Horn Remains Pressed, Power On

**⚠ In up-right drive mode, vehicle will move when handle is operated at any position. Please avoid misoperation.**

**⚠ Brake release mode is only for emergencies, not allowed for vehicle with normal conditions.**

# CHARACTERISTICS

- Horn
- Emergency reverse button
- Forward/reverse butterfly switch
- Lifting / Lowering
- LCD Screen
  - Battery indicator with hour meter
  - Error code display
  - Recharge Alert

**Multi-function Handle (Full Electric)**

**Multi-function Ergonomic Handle (Semi-electric)**

# OPTIONS

- Tandem/Single PU wheel
- 15Ah Lithium Battery
- Fast Charger 2hrs
- Intelligent Control Key

**BUILT TO WORK 24 HOURS**

**SMART SIZE ALMOST SAME**

**LIGHT WEIGHT**  
ELECTRIC PALLET TRUCK ONLY 125kgs vs HAND PALLET TRUCK 80 kgs

**EASY MAINTENANCE**

**LIFETIME**  
3 Times Longer Than Manual Pallet Truck

**1 PCS VS 3 PCS**

**PAY A LITTLE MORE SAVE MUCH MORE**

# MAINTENANCE SO EASY

**5 YEAR WARRANTY CHASSIS**

- Brushless drive motor, maintenance free
- Lithium-ion battery maintenance free
- Recharge Alert
- Error code display
- 6s Replace Battery
- 60s Replace Drive Wheel

- Protection cover
- Electric Lifting/Lowering
- Lithium battery pack
- Battery Protection Stopper