

**POWERFUL TRUCKS**



## X Series Heavy IC Forklift Trucks

with capacities of 14,000 to 18,000kg



**ZHEJIANG HANGCHA IMP. & EXP. CO., LTD.**

**Factory site:** 666 Xiangfu Road,  
Hangzhou, Zhejiang, China (311305)

Tel: +86-571-88926735 88926755  
Fax: +86-571-88926789 88132890

sales@hcforklift.com  
www.hcforklift.com

 Follow us on Facebook  
 Follow us on YouTube  
 Follow us on WeChat  
 Available on the App Store  
 Get it on Google play  
Download "Hangcha Forklift" App

 ISO14001  
 ISO9001:2015  
 HANGCHA trucks conform to the European Safety Requirements.

HANGCHA GROUP CO., LTD. reserves the right to make any changes without notice concerning colors, equipment, or specifications detailed in this brochure, or to discontinue individual models. The colors of trucks, delivered may differ slightly from those in brochures.

2020 VERSION 2/COPYRIGHT 2020/09

*The World of Hangcha*



# X SERIES HEAVY IC FORKLIFT TRUCKS

The heavy load X series is extension of the new series of internal combustion counterbalance forklift truck developed by Hangcha independently, adopting the world advanced technologies based on the original products. Through the comprehensive upgrading of appearance molding, energy conservation, environmental protection, comfort, security and reliability, it will become the world-class forklift truck which can meet your overall demands.

## CHARACTERISTICS

The truck has professional and entirely-new appearance, has great identifiable degree, has simple and smooth profiling and has great industrial aesthetics. The exposed parts are arranged in concealed manner, and the appearance is more concise.

The key parts are products of internationally well-known brands, have been utilized in the products of previous models, have been validated by the market, and are reliable and durable; The modular and standard design is applicable, the main parts are validated in advance and by steps, the truck has great maturity.



# Easy/ Efficiency/ Economy



## STAGE V & TIER 4F

### HANGCHA with you at every stage

Efficient, reliable solutions for your demands

With Hangcha you can meet all Stage V/Tier 4f emissions standards which provides customer demands for value, innovation and performance. The technologies include common rail fuel systems, Turbocharged Inter-cooled selective catalytic reduction (SCR), diesel oxidation catalysts (DOC) and diesel particulate filters (DPF). Designed and optimised to every engine model, our forklift truck maximises efficiency and reliability.

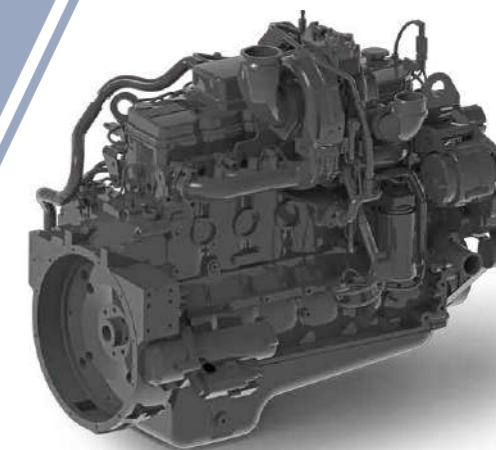

CUMMINS B6.7

### High Performance

The performance is improved. The travel speed and lift speed are improved by 10%-20%. The body of the truck is reduced, and the flexibility is strengthened. Thanks to CAE (Computer Aided Engineering) technology, structural components are more balanced.

### Comfort

With the new-style fully-suspended and overall-view cab. The profile of the truck is optimized; The vision is more excellent. The interior ornaments are formed, feeling is more comfortable; Shaped steel tube integral frame provides high strength and better sealing.

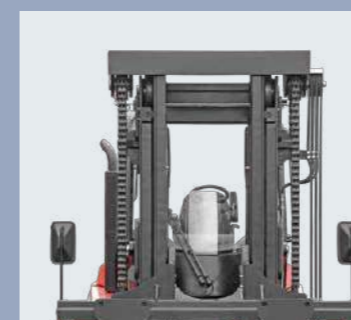
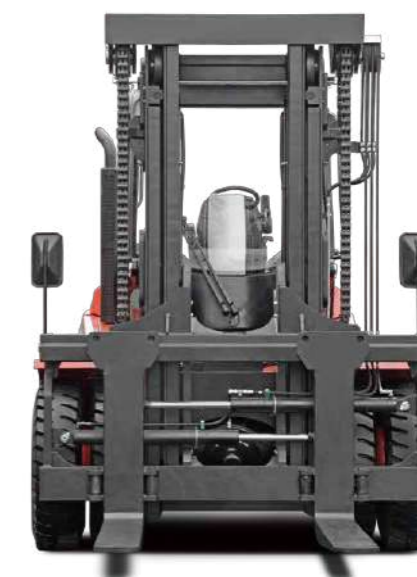

Excellent all round visibility is achieved by the overall design.



Thanks to the unique design, cab can be tilt without any tools, major service items can be reached easily by tilting the cabin, maximized access is possible.



Optional imaging system with front and rear camera, increasing the safety greatly.



ZF gear box with micro-electronic control provides for three-shift power shifting, travelling is stable and accurate.



Load sensing hydraulics provide high efficiency and energy saving, reducing hydraulic oil working temperature and also extending the life of hydraulic components and seals.



Anti-slip pedal provides high safety and easy maintenance.



Battery compartment is easy to open for easy maintenance.



The newly designed LCD instrument has more comprehensive functions and more stable performance. It can display the important information such as truck status and engine faults... So that the operator can understand the truck status more intuitively and facilitate maintenance.



Suspended seat with fingertip system that can be easily adjusted to suit each customer.



KESSLER heavy-duty traction axle, two-stage deceleration; Wet brake, maintenance-free; Hydraulic release spring action parking brake, safe and reliable.



## Standard Specification

- / Duplex mast
- / Single control lever - Fork position operation
- / Cooling/heating air-conditioner
- / Fully-hydraulic power steering
- / Quadruple multi-way valve
- / OPS system
- / Adjustable steering column
- / Tip-over oil circuit self-lock valve
- / Lifting speed limit valve
- / High-position exhaust
- / Traction device
- / Power-off switch
- / Reversing radar
- / CAN-bus structure indicator
- / LED lamps
- / Pneumatic tyre
- / Reversing buzzer
- / Snail horn
- / Manual tilting cab
- / Adjustable armrest
- / Tools

## Options

- / Customer color
- / Special forks
- / Portals of other specifications
- / Solid tyre
- / On-board interphone
- / Audible warning reverse alarm
- / Alarm lamp
- / Video monitoring system
- / Spark extinguisher
- / Fire extinguisher (2kg/4kg)
- / Automatic fire extinguishing device
- / LED work lamp
- / Four-circuit driving recording system
- / Speed limit device
- / Blue lamp
- / Weighing system
- / Air pre-filter
- / Electrostatic conduction chain
- / Fan
- / Electro-hydraulic tilting cab

## Reliability

Increased digitization, additional central controller, CAN-bus structure, built-in multiple diagnostic, management functions and fault alarm are convenient for diagnosis.

## Precise Operation

Integrated fingertip system, pilot control, smart and accurate; Hydraulic brake curve optimization, smooth and easy control.

