

Technical Data

Parameter items	unit	HV120AJ
Max. working height	m	12
Max. platform height	m	10
Horizontal extension distance	m	5.5-0.5
Horizontal height	m	5.99
Capacity	kg	200
Length	m	3.9
Width	m	1.2
Height	m	1.98
Ground clearance (to center of frame)	mm	120
Ground clearance (to anti-overturning plate)	mm	80
Turret rotation	°	345
Platform rotation	°	120
Short jib swing angle	°	+65/-60
wheel base	m	1.6
Turning radius(inside)	m	0.75
Turning radius(outside)	m	2.6
Platform length	m	0.8
Platform width	m	1.2
Tire size	mm	454*178
Battery	V / Ah	48 / 160 (lithium battery) / 200 (lead acid battery)
Charger	V / A	48 / 40
Max. Travelling speed	km/h	6
Max. Travelling speed (working status)	km/h	0.5
Max. slop rating	%	30
Maximum allowable inclination	°	3
Driving motor	Kw	2*1.5
Oil pump motor	Kw	6
Weight	kg	5000

Features

Truck	Standard	Options
Self-propelled	●	
No marking tyre	●	
4 X 2 drive	●	
345° non-continuous turret turning	●	
Swing cover	●	
Lithium battery		○
AC power socket preset value		○
The proportional joystick	●	
Controls and instruments		
Emergency lower system	●	
Emergency stop system	●	
Safety		
The anti-overturning system	●	
Automatic break system	●	
Explosion proof valve	●	
Fault diagnosis	●	
Self-leveling system	●	
Full motion alarm		○
Height limit anti-collision rod		○
Anti-pinch device in the basket		○
Lights		
Flashing light	●	
Work lamp		○

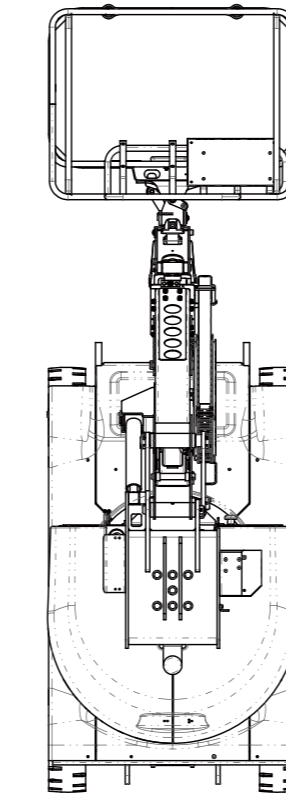
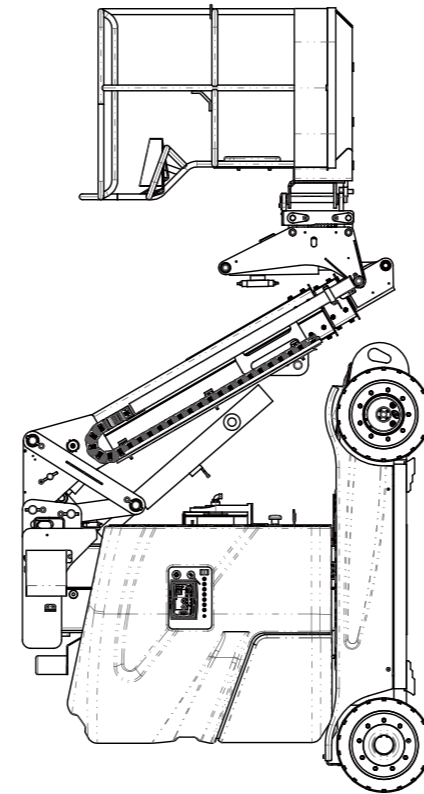
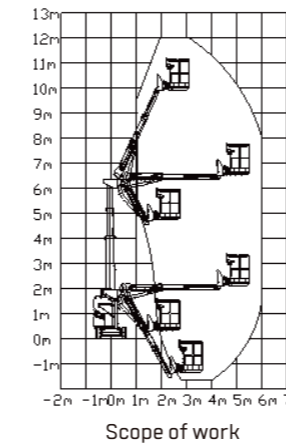
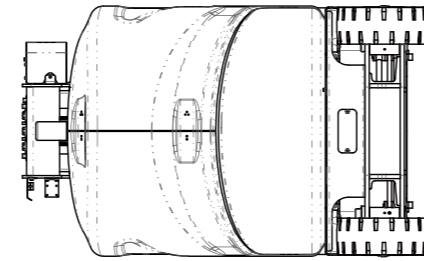

HANGCHA GROUP CO., LTD.

Factory site: 666 Xiangfu Road,
Hangzhou, Zhejiang, China (311305)

Tel: +86-571-88926735 88926755
Fax: +86-571-88926789 88132890

sales@hcforklift.com www.hcforklift.com

HANGCHA GROUP CO., LTD. reserves the right to make any changes without notice concerning colors, equipment, or specifications detailed in this brochure, or to discontinue individual models. The colors of trucks, delivered may differ slightly from those in brochures.



Follow us on
Facebook



Follow us on
YouTube



Follow us on
WeChat



Download "Hangcha
Forklift" App



ISO45001:2018



ISO14001:2015



ISO9001:2015



HANGCHA trucks conform
to the European Safety
Requirements.



HV120AJ

VERTICAL MAST LIFT

HV120AJ

VERTICAL MAST LIFT

Your reliable, powerful and connected working machine.



EVERY JOB IS IN YOUR REACH



MACHINE CHARACTERISTICS

- Equipped with overload sensing system, tilt alarm, emergency lower system and other perfect safety configuration.
- Mast and flying jib self-weight ratio decreased, zero energy consumption, make it stronger endurance.
- Automatic hydraulic leveling of the work platform, smooth without impact.
- High quality guarantee, excellent performance, safety and reliability.
- AC drive system is energy-saving and efficient, the motor is maintenance-free, and full movement speed use proportional control system.
- Compact structure: 1.2 meters ultra-narrow body, 2.6 meters turning radius(outside), it has good passability.

1200mm
ULTRA-NARROW BODY

2600mm
TURNING RADIUS



Built-in wide voltage smart charger, make it convenient energy supplement.



The machine is equipped with the CAN BUS control system and easy for troubleshooting.



Standard lead-acid battery, optional lithium battery, five years warranty.

WORKS LIKE AN EXTENSION OF YOU

Three-level telescopic flying jib + basket horizontal rotation, make it wider working range.

